



 GENERI, s.r.o. Uničovská 50 787 01 ŠUMPERK Czech Republic tel.: +420583221500, fax: +420583214183	OPERATING INSTRUCTIONS		Page: 1 of 3
	EXPLOSION-PROOF CONTROL, MEASURING AND INDICATION BOXES		N740019/5 – 4 nd issue
	TYPE: X.SA. (0 - aluminium, 1- polyester, 2 – stainless steel)		

GENERAL

These operating instructions conform to:

- *Technical requirements for equipment and protective systems intended for use in potentially explosive atmospheres (2014/34/EU).*
- *Technical requirements for products from the point of their electromagnetic compatibility (2014/30/EU).*

SAFETY INSTRUCTIONS AND UNSUITABLE USE

Do not leave these operation instructions inside the box during operation!

- **Avoid any mechanical damage** of the box when manipulating!
- Explosion-proof boxes X.SA. **are not intended for untrained personnel.** Installation, commissioning and any service must be performed by authorized personnel with the appropriate training and in accordance with safety rules.
- **Do not open boxes X.SA. when energized!**
- **Operate boxes X.SA. in accordance with below mentioned operating conditions, technical and rating label data.**
- **Do not operate boxes X.SA. in hazardous areas zone 0** (EN 60 079-10-1) and zone **20** (EN 60 079-10-2)!
- **Only boxes X.SA1 and X.SA2 can be operated in the underground mines with occurrence of methane (group I)!**
- **Do not replace original interior content** of the boxes with components that are in contradiction to documentation supplied with boxes (e.g. switching units, signal lamps...)
- Switching units inside control boxes may **produce short-time electromagnetic interference** so they must be operated in areas where no negative influence to other equipments is.
- Storage, transport, mounting, installation, inspection and preventive maintenance, repairs and service to be executed according to following instructions.

1. USING

Explosion-proof control and indication boxes X.SA. are used for installation in hazardous areas with risks of explosion of inflammable gases, vapors, dusts and explosives respectively in the underground mines with occurrence of methane.

2. OPERATING CONDITIONS

2.1. External influences acc.to IEC 60 364-5-51-cat.A: ENVIRONMENT

Code	Description of external influence	Specification
AA	Ambient temperature (maximal range)*	-60°C to +80°C
AB	Atmospheric humidity	to +30°C ... 100% to +40°C ... 70%
AD5	Presence of water	Jets
AE6	Presence of foreign solid bodies or dust	Heavy dust
AF4	Presence of corrosive or polluting substances	Continuous
AG3	Mechanical shock	High severity (7J)
AH	Vibrations	See art. 6. – Rev.

* Concrete temperature range depends on used components and it is always mentioned on name plate, if the equipment is produced for ambient temperature range different than standard range -20°C to +40°C.

2.2. External influences acc.to IEC 60 364-5-51-cat.B: USE

Code	Description of external influence	Specification
BE3N1	Explosion risks of inflammable dusts	see point 2.4
BE3N2	Explosion risks of inflammable gases and vapours	see point 2.4
BE3N3	Fire or explosion risks of explosives	see point 2.4
BA5	Capability of persons	Skilled
BC3	Contact of persons with earth potential	Frequent

2.3. Not mentioned external influences are in accordance with IEC 60 364-5-51 normal.

2.4. Use in areas and environments according to regulations

Areas	Name of standard	Standard
Potentially explosive atmospheres	Explosive atmospheres - Explosion prevention and protection - Part 2: Basic concepts and methodology for mining	EN 1127-2
ZONE 1 ZONE 2	Explosive atmospheres - Part 10-1: Classification of areas - Explosive gas atmospheres	EN 60 079-10-1
ZONE 21 ZONE 22	Explosive atmospheres - Part 10-2: Classification of areas - Combustible dust atmospheres	EN 60 079-10-2

2.5. Operating position: vertical

3. TECHNICAL DATA

3.1. General

Name	Specification	Standard, note.	
Type of protection *	Ex db eb mb IIC T* Gb Ex tb IIC T*°C Db Ex db eb mb I Mb (X.SA1, X.SA2)	EN 60 079-0 EN 60 079-1 EN 60 079-7 EN 60 079-18 EN 60 079-31	
Ingress protection	IP 65	EN 60 529	
Group and category	II 2G, II 2D I M2 (X.SA1, X.SA2)	2014/34/EU	
Certification	FTZÚ 07 ATEX0068	FTZÚ NB 1026, CZ	
Electromagnetic compatibility	Resistant to elm. interference Radiating short-term elm. interference	Acc.to EN 60 947-3 no other verification is required	
Material	X.SA0	Al-pressure die casting DIN 1725 (AlSi12)	
	X.SA1	Glass fiber reinforced polyester (GRP) with addition of graphite	black, equivalent to RAL 9011 or RAL 9005
	X.SA2	stainless steel plate 1.4301 / 304	DIN / ASTM Other material on request
Surface finish of X.SA0	Powder baking coating	Grey, RAL 7001	
Combustibility of X.SA1	Hardly inflammable and self-extinguishing	UL – S94.V – 0 (also halogen-free)	
External PE (X.SA0, X.SA2)	16 mm ²	2x screw M5 with clamping plate	

* Concrete data are mentioned on rating plate.

3.2. Contact elements ZBWE***:

Name	Specification	Standard, note.
Rated thermal current I _{th}	10 A	-
Rated power	AC15 240V	3A
	DC13 250V	0,27A
		EN 60 947-5-1
Rated voltage U _i	415V	-
Insulation category	Group C	-
Type of contact	Dependent switching	1/0 (N/O), 0/1 (N/C)
Terminals marking	1 - 2 for 0/1 (N/C) 3 - 4 for 1/0 (N/O)	-
Fusing	Fast fuse g1 or N 10A	IEC 337-1B, VDE 0660
Connection	min. 1 x 0,5 mm ² max. 1 x 2,5 mm ² max. 2 x 1,5 mm ²	Stranded conductors shall be equipped with a ferrule
Torque	0,8Nm (max.1,2Nm)	

 GENERI, s.r.o. Uničovská 50 787 01 ŠUMPERK Czech Republic tel.: +420583221500, fax: +420583214183	OPERATING INSTRUCTIONS		Page: 2 of 3
	EXPLOSION-PROOF CONTROL, MEASURING AND INDICATION BOXES		N740019/5 – 4 nd issue
	TYPE: X.SA. (0 - aluminium, 1- polyester, 2 – stainless steel)		Valid from: 15.6.2022

4. INSTALLATION INSTRUCTIONS

4.1 Mounting of the boxes

4.1.1 Boxes X.SA0, X.SA1

Spacing of mounting holes is stated on the bottom of the box. Lift off the cover, insert attachment screws into holes and mount the box.

4.1.2. Boxes X.SA2

There are two various ways:

- By screws M6 that you screw up into "blind" holes in the box bottom from outwards.
- By stainless steel screws M6 from outwards of the box you screw up into the "blind" holes in the box bottom and herewith by them you fix special stainless steel flanges (all is delivered as accessories of box). The box equipped by this way you can fix from the front by screws M8 that you put into the whole in flanges.

4.2 Cables entries

Each cable gland can seal only a certain range of outside diameters of cables. In the case of more quantity of cable glands placed on the flange of box it is necessary to insert and tighten the cable into the cable gland subsequently from one side to the other side (for instance from the left to the right) and also to start with cable gland on the lower row and continue with the cable glands on the upon them.



For easier mounting of cable glands it is possible to deliver special tighten tongs – see picture.

To achieve a reliable ingress protection properly tightens the cable glands by specified tightening torque.

Unused holes and openings for cable entries must be closed by certified plugs that comply with required degree and type of protection - see art.6.

4.3 Connection of wires to terminals

There are used either the cage clamp terminals or screw terminals. Their function is clear from the following pictures.

4.3.1. Cage spring terminals

By pressing a cage clamp of the terminal block (1) e.g. with a suitable screwdriver (or a special WAGO screwdriver supplied by customer's request) you unfasten space for the connection of a wire. By pushing of the wire (2) and releasing the cage clamp (3) a perfect current-carrying connection is created.

At connection of two adjacent terminal block with cage clamp by means of special blade jumper, press this jumper with power into both terminal blocks so that it does not overreach the terminal block (see following picture)

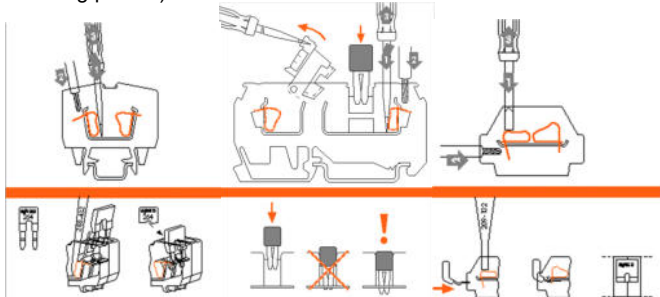

At some types of terminals with cage clamp it is necessary to use a greater one terminal when connecting a wire with a ferrule. E.g. for connection of a 2,5 mm² wire with the ferrule, it is necessary to use a terminal block 4,0 mm².

4.3.2. Screw terminals

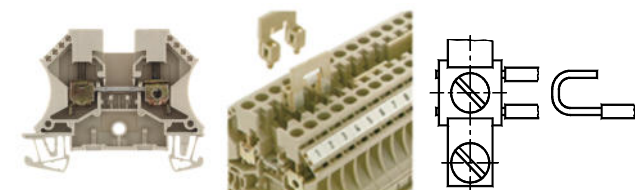

Connect wires from the side of the terminal and properly tight the connection. If you **interconnect screw terminals** (see previous picture), properly tight screw jumpers.

If the PE or FE rail is installed and only one wire is to be connected to a terminal, it is necessary to bend the end of wire into a "U" shape so that the clamping plate compressing the wire is in-plane and the

function of the flexible washer between the clamping plate and the screw head is not reduced.

4.3.3. General requirements

Stranded conductors shall be equipped with a ferrule. We recommend use ferrules also for full copper wires without surface protection and in **aggressive atmosphere**. The termination of stranded wires only by soft solder is not permitted!

You can insert only one wire in to the connection hole of terminal and **its cross section must not exceed nominal cross section of terminal, which is mentioned on the terminal block or on the rating plate.**

The wire insulation must reach as close the current-carrying connection as possible. The wire must not be damaged.

We recommend regularly **treat connection points of protection wires** (or other corrosive metal surfaces) with **grease**, at least 1 a year (depending on the environment). It is not valid for stainless steel boxes.

Unused dead wires should be connected to unoccupied terminal (including of protective wires) or terminated in a way complying with valid regulations

Use of Al-wires with the cross section < 16 mm² is PROHIBITED!

5. INSTALLATION ACC. TO VALID REGULATIONS

A decision to use a given type of equipment in particular areas must comply with said operating conditions (see point 2.), local operating regulations, **EN 60 079-14**, and other valid regulations.

Electrical accident protection is, in addition to said regulations, stipulated by **IEC 60 364-4-41**, **EN 61 140** and other related regulations. Safety regulations for operating personnel and work on electrical equipment are identified by **EN 50 110-1**.

6. INSPECTION AND PREVENTIVE MAINTENANCE

Inspection and preventive maintenance of explosion-proof electrical equipment is determined by EN 60 079-17 (unless determined otherwise by a notice, local regulations etc.).

The boxes of explosion proof electrical equipment X.X. can be opened only **while are not energized!**

All mechanical and electrical connections are protected from self-loosening (EN 60 079-7). Vibration tests of equipment (external effects AH1, 2, 3 by IEC 60 364-5-51) in relation to classes of climatic conditions by EN 60 721-3-3 and EN 60 721-3-4 are not however performed. That is why, in case of **mobile equipment**, we recommend **carry out inspections at least 2-times a year as a detailed inspection according to EN 60 079-17.**

Cable glands and plugs can be replaced only by types with appropriate type of Ex and ingress protection and certified by the notified body. Where it is not possible to provide fixed installation of cables, it is necessary to use cable glands with a protection against pulling out (usually with clamping module) - it relates mostly to **mobile equipment.**

Other spare parts - see article 10.

7. REPAIRS AND MAJOR INSPECTIONS, SERVICE

Repairs and major inspections of explosion-proof electrical equipment are based on **EN 60 079-19**.

Repairs should be carried out only by the manufacturer or an organization authorized by the manufacturer.

The following parts **must not be repaired**:

- Inspection window in the cover
- Ex components (terminals, switching and indication units, A-meters)
- Cable glands and plugs
- Sealing box-cover
- Stainless steel screws in the cover

These parts must be replaced if damaged.

Ex type of protection and original ingress protection must be preserved in case of any repairs and renovations.

Service is performed right in the manufacturing plant in Šumperk.

In case of any problems regarding the GENERI products (such as loss of accompanying documents, technical defects etc.), just read the two data on the rating plate:

- 1) **TYPE OF EQUIPMENT**
- 2) **SERIAL NUMBER**

On the basis of these data it is possible to find any accompanying and technical documents of concrete product at manufacturer.

8. STORAGE, PACKING AND TRANSPORT

Explosion-proof boxes X.SA. are **stored** at the ambient temperature of +5°C to +40°C, in non-aggressive interior areas without the UV radiation and weather conditions where the quality does not deteriorate (climatic conditions 1K2, biological conditions 1B1, active chemical compounds 1C2, mechanically active substances 1S1, and mechanical conditions 1M2 according to EN 60 721-3-1).

Boxes are **packed** in protective foils and supplied in cardboard boxes (bigger boxes can be attached to pallets).

Transport is provided by an express transport company within 24 hours, or according to request. It is also possible to cash on delivery. Transport conditions are 2K2, 2B1, 2C2, 2S1, 2M2 by EN 60 721-3-2.

9. DELIVERY TERMS

Price of goods, delivery terms, methods of payment and transport are mentioned in a purchase contract which is sent by the business department after receiving your order. If it is not specified otherwise in the contract, a standard warranty 12 months for goods is provided.

10. SPARE PARTS

Exact specification of particular electrical components is listed in wiring diagram supplied with each box.



11. PRODUCT DISPOSAL

Useless products should be disposed in accordance with valid regulations.

!!! All components may produce harmful exhalations during combustion!!!

12. DOCUMENTS SUPPLIED WITH THE PRODUCT

- 📄 EU declaration of conformity
- 📄 These operation instructions incl. of warranty
- 📄 Wiring diagram inserted inside the box
- 📄 Delivery note

Certificates according to point 3 are available on www.generi.cz or upon request.



*WE WISH YOU MAXIMUM
SATISFACTION WITH OUR
PRODUCTS AND SERVICES*

WARRANTY

Product type:	X.SA0	X.SA1	X.SA2
Mark::	<input type="checkbox"/>	<input type="checkbox"/>	<input type="checkbox"/>
Serial number	from:		to:
No.:			

You are provided with a warranty for a period of 12 months (if it is not specified otherwise in the purchase contract) valid from the day the product was handed over. We guarantee quality of work and material. Despite this, faults unidentifiable in the manufacturing plant may occur due to storage, during transport or use. If they were caused by faulty material or production, we shall restore the product to a trouble-free state at our own costs. The warranty does not apply to defects resulting from mishandling or mechanical damage and not following instructions for assembly and maintenance.

FINAL INSPECTION

Authorized person:	Result:	Stamp and signature:
	OK	

